



**EN** Operating instructions. . . . .pages 1 to 6  
Translation of the original operating instructions

**Content**

**1 About this document**  
1.1 Function . . . . .1  
1.2 Target group: authorised qualified personnel. . . . .1  
1.3 Explanation of the symbols used . . . . .1  
1.4 Appropriate use . . . . .1  
1.5 General safety instructions . . . . .1  
1.6 Warning about misuse . . . . .2  
1.7 Exclusion of liability . . . . .2

**2 Product description**  
2.1 Ordering code . . . . .2  
2.2 Special versions. . . . .2  
2.3 Destination and use . . . . .2  
2.4 Technical data . . . . .2  
2.5 Safety classification . . . . .3

**3 Mounting**  
3.1 General mounting instructions . . . . .3  
3.2 Dimensions . . . . .3

**4 Electrical connection**  
4.1 General information for electrical connection. . . . .4

**5 Functions and configuration**  
5.1 Mode of operation of the safety outputs. . . . .4  
5.2 Magnet control . . . . .4  
5.3 Description of the latching and the latching force adjustment . . . . .4  
5.4 Programming the slave address . . . . .4  
5.5 Configuration of the safety monitor . . . . .4  
5.6 Status signal "safety release" . . . . .4  
5.7 Violent separation of solenoid interlock and actuator . . . . .4

**6 Diagnostic**  
6.1 LED indications . . . . .4  
6.2 Error . . . . .4  
6.3 Locking of the solenoid interlock blocked . . . . .4  
6.4 Diagnostic information . . . . .5  
6.5 Diagnostic signal periphery error . . . . .5  
6.6 Read-out of the parameter port . . . . .5

**7 Set-up and maintenance**  
7.1 Functional testing. . . . .5  
7.2 Maintenance . . . . .5

**8 Disassembly and disposal**  
8.1 Disassembly. . . . .5  
8.2 Disposal . . . . .5

**9 Appendix**  
9.1 EC Declaration of conformity . . . . .6

**1. About this document**

**1.1 Function**

This operating instructions manual provides all the information you need for the mounting, set-up and commissioning to ensure the safe operation and disassembly of the safety switchgear. The operating instructions must be available in a legible condition and a complete version in the vicinity of the device.

**1.2 Target group: authorised qualified personnel**

All operations described in this operating instructions manual must be carried out by trained specialist personnel, authorised by the plant operator only.

Please make sure that you have read and understood these operating instructions and that you know all applicable legislations regarding occupational safety and accident prevention prior to installation and putting the component into operation.

The machine builder must carefully select the harmonised standards to be complied with as well as other technical specifications for the selection, mounting and integration of the components.

**1.3 Explanation of the symbols used**



**Information, hint, note:**

This symbol is used for identifying useful additional information.



**Caution:** Failure to comply with this warning notice could lead to failures or malfunctions.

**Warning:** Failure to comply with this warning notice could lead to physical injury and/or damage to the machine.

**1.4 Appropriate use**

The products described in these operating instructions are developed to execute safety-related functions as part of an entire plant or machine. It is the responsibility of the manufacturer of a machine or plant to ensure the correct functionality of the entire machinery or plant.

The safety switchgear must be exclusively used in accordance with the versions listed below or for the applications authorised by the manufacturer. Detailed information regarding the range of applications can be found in the chapter "Product description".

**1.5 General safety instructions**

The user must observe the safety instructions in this operating instructions manual, the country-specific installation standards as well as all prevailing safety regulations and accident prevention rules.



Further technical information can be found in the Schmersal catalogues or in the online catalogue on the Internet: [www.schmersal.net](http://www.schmersal.net).

The information contained in this operating instructions manual is provided without liability and is subject to technical modifications.

There are no residual risks, provided that the safety instructions as well as the instructions regarding mounting, commissioning, operation and maintenance are observed.

### 1.6 Warning about misuse



In case of inadequate or improper use or manipulations of the safety switchgear, personal hazards or damage to machinery or plant components cannot be excluded. The relevant requirements of the standard EN 1088 must be observed.

### 1.7 Exclusion of liability

We shall accept no liability for damages and malfunctions resulting from defective mounting or failure to comply with this operating instructions manual. The manufacturer shall accept no liability for damages resulting from the use of unauthorised spare parts or accessories.

For safety reasons, invasive work on the device as well as arbitrary repairs, conversions and modifications to the device are strictly forbidden; the manufacturer shall accept no liability for damages resulting from such invasive work, arbitrary repairs, conversions and/or modifications to the device.

## 2. Product description

### 2.1 Ordering code

This operating instructions manual applies to the following types:

#### MZM 100 ① ST-AS ②③AP

No.	Option	Description
①	B	Solenoid interlock monitored Actuator monitored
②	RE	without electrical latching (only for variant "solenoid interlock monitored") Latching force, adjustable, approx. 30 N ... 100 N
③	M	without Permanent magnet with Permanent magnet approx. 30 N
	A	Power to lock
	P	Device supplied through auxiliary voltage

**MZM 100-B1.1** actuator



Only if the information described in this operating instructions manual are realised correctly, the safety function and therefore the compliance with the Machinery Directive is maintained.

### 2.2 Special versions

For special versions, which are not listed in the order code below 2.1, these specifications apply accordingly, provided that they correspond to the standard version.

### 2.3 Destination and use

The MZM 100 AS is designed for application with AS-Interface Safety at Work and is used for monitoring the position of movable separating safety guards. A door detection sensor monitors the closed condition of the safety guard. A safe magnetic force monitoring detects when the latching force drops below a defined latching force. The different variants can be used as safety switch with interlocking function either as solenoid interlock.

The safety function of the MZM 100 AS consists in safely switching off the code transmission when the safety guard is opened and maintaining the safe switched off condition for as long as the safety guard is open.

An AS-Interface Safety at Work component functions on the basis of an individual code generator (8 x 4 bit). This safety code is cyclically transmitted over the AS-i network and monitored by an ASM safety monitor.



For an application with safe monitoring of the interlocking function, the MZM 100 ST-AS variant must be selected. The MZM 100 B ST-AS variant is a safety switch with additional locking function.

The latching force F of the MZM 100 AS solenoid interlock is permanently measured and checked.

In this way, soiling of the solenoid interlock can be detected. If the latching force drops below 500 N, the AS-i Safety codes are not enabled.



Interlocks with power to lock principle may only be used in special cases after a thorough evaluation of the accident risk, since the safety guard can be opened immediately on failure of the power supply or upon activation of the main switch.



The user must evaluate and design the safety chain in accordance with the relevant standards and the required safety level.

### 2.4 Technical data

Standards: EN 50295, EN 60947-5-1, IEC 61508, EN ISO 13849-1, IEC 60947-5-3

Working principle:	inductive
Material of the housings:	Plastic, glass-fibre reinforced thermoplastic, self-extinguishing
Response time:	< 100 ms
Duration of risk:	< 100 ms
Time to readiness:	< 4000 ms
Recommended actuator:	MZM 100-B1.1

#### Mechanical data

Execution of the electrical connection:	M12 connector plug, 4 poles
Mechanical life:	> 1,000,000 operations (for safety guards ≤ 5 kg; actuating speed: ≤ 0.5 m/s)
Resistance to shock:	30 g / 11 ms
Resistance to vibration:	10 Hz ... 150 Hz (0.35 mm / 5 g)
Holding force F <sub>max</sub> :	750 N
Holding force F guaranteed:	500 N
Electrically adjustable latching force:	approx. 30 ... 100 N
Permanent magnet (M):	approx. 30 N
Tightening torque for device fixation:	max. 8 Nm

#### Ambient conditions

Ambient temperature:	-25 °C ... +55 °C
Storage and transport temperature:	-25 °C ... +85 °C
Relative humidity:	30 ... 95%, no condensation, no icing
Protection class:	IP67 to IEC/EN 60529
Protection class:	II, II

#### Insulation values to IEC/EN 60664-1:

- Rated impulse withstand voltage U <sub>imp</sub> :	0.8 kV
- Rated insulation voltage U <sub>i</sub> :	32 VDC
- Overvoltage category:	III
- Degree of pollution:	3

#### Electrical data - AS-Interface

AS-i supply voltage: 26.5 ... 31.6 VDC, protection against polarity reversal

AS-i power consumption: ≤ 100 mA

AS-i device insulation: internal short-circuit proof

AS-i specification:  
- Version: V 2.1  
- Profile: S-7 B

AS-i inputs:  
- Channel 1: Data bits DI 0/DI 1 = dynamic code transmission  
- Channel 2: Data bits DI 2/DI 3 = dynamic code transmission  
Databits condition static 0 or dynamic code transmission

AS-i outputs:  
- DO 0: magnet control  
- DO 1 ... DO 3: Latching force adjustment in 10 N steps

AS-i Parameter bits:  
- P0: Actuator in  
- P1: Solenoid interlock locked  
- P2: Auxiliary voltage in  
- P3: Internal device error

Parameter request: default value parameter request "1111" (0xF)  
 AS-i Input module address: 0  
 - preset to address 0, can be changed through AS-interface bus master or hand-held programming device

### Electrical data - auxiliary voltage (Aux)

Supply voltage  $U_B$ : 24 VDC (-15 % / +10 %) protection against polarity reversal; stabilised PELV units  
 Power consumption:  $\leq 600$  mA  
 Magnet switch-on time ED: 100 %  
 Device fuse rating:  $\leq 4$  A (when used to UL 508)

### LED switching conditions display:

(1) LED green-red (AS-i Duo LED): Supply voltage / communication error / slave address = 0 or periphery error detected  
 (2) LED red: Internal device error  
 (3) LED yellow: Device condition (Enabling status)

⚠ If the cable and connector assembly is not listed for Type 12 or higher, then the device MZM 100 ... shall be used in a Type 1 environment only. Use isolated power supply only. For use in NFPA 79 Applications only. Adapters providing field wiring means are available from the manufacturer. Refer to manufacturers information.

### 2.5 Safety classification

Standards: EN ISO 13849-1, IEC 61508, IEC 60947-5-3  
 PL: up to e  
 Control category: up to 4  
 PFH value:  $\leq 5.0 \times 10^{-9}$  / h  
 SIL: up to 3  
 Service life: 20 years  
 Classification: PDF-M

## 3. Mounting

### 3.1 General mounting instructions

For fitting the MZM 100 AS and the actuator, two mounting holes for M6 screws with washers (washers included in delivery) are provided.



The safety switchgear must be used as end stop.

For safe operation of the system, the angle between the safety switch and the actuator compulsory must be  $\leq 2^\circ$ . After fitting, the unused fixing holes must be covered by means of the provided blanking plugs. To remove these plugs, if required, exert pressure on the topmost extremity (when the connector is fitted downwards) or press on the right-hand side of the plugs on the anchorage plate of the actuator.



Safety sensor and actuator must be permanently fitted to the safety guards and protected against displacement by suitable measures (tamperproof screws, gluing, drilling, pinning).



At an ambient temperature of  $\geq 50^\circ\text{C}$ , the MZM 100 AS must be fitted so that it is protected against unintentional contact with persons. Please observe the remarks of the standards EN ISO 12100, EN 953 and EN 1088.



The safety component must be operated in the operating direction of the latching force (refer to image).

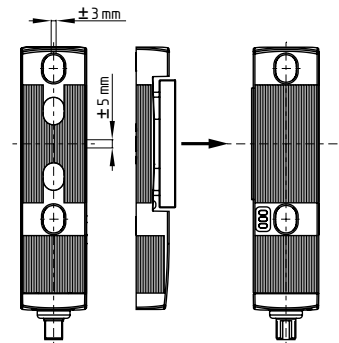

### 3.2 Dimensions

All measurements in mm.

#### safety switchgear

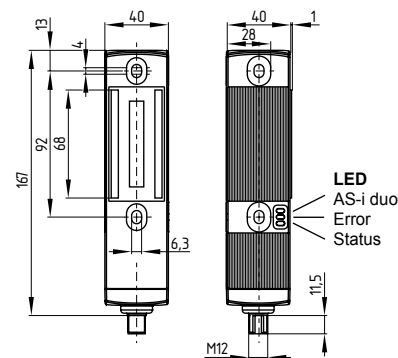

#### Actuator

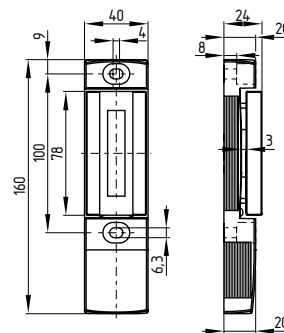

### 4. Electrical connection

#### 4.1 General information for electrical connection



The electrical connection may only be carried out by authorised personnel in a de-energised condition.

The MZM 100 AS safety switchgear and the interlocking solenoid are supplied from the auxiliary energy. The AS-Interface node is supplied from AS-i. Both voltage supplies of the safety switchgear must be equipped with protection against permanent overvoltage. To that effect, stabilised PELV supply units must be used. The connection to the AS-Interface system is realised through an M12 connector. The M12 connector is A-coded. The wiring configuration of the M12 connector is defined as follows (to EN 50295):

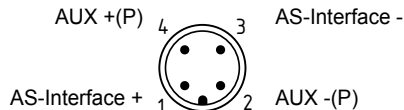

### 5. Functions and configuration

#### 5.1 Mode of operation of the safety outputs

##### MZM 100 ST-AS ...

The safety outputs of the AS-i safety monitor are enabled, when the following conditions are met:

- the actuator has been detected
- the interlock is locked, the magnetic force is > 500 N

##### MZM 100 B ST-AS ...

The safety outputs of the AS-i safety monitor are enabled, when the following conditions are met:

- the actuator has been detected, the latching force is active
- locking with magnetic force > 500 N possible

#### 5.2 Magnet control

The control system with the AS-Interface Master can lock and unlock the solenoid interlock through the output bit 0 of the addressed AS-i slave. To lock the interlock, output bit DO 0 of the MZM 100 AS must be set to "1" by the control.

#### 5.3 Description of the latching and the latching force adjustment

The latching force exercised by the permanent magnet (M) keeps the safety guard closed, also in de-energised condition (approx. 30 N). The electrical latching is activated by the detection of the actuator when the safety guard is closed.

The latching force can be set through the control by means of the output bits DO 1... DO 3 of the addressed AS-i Slave MZM 100 AS, in 8 stages.

DO	3	2	1	Latching force RE	Latching force REM
	0	0	0	approx. 30 N	approx. 60 N
	0	0	1	approx. 40 N	approx. 70 N
	0	1	0	approx. 50 N	approx. 80 N
	0	1	1	approx. 60 N	approx. 90 N
	1	0	0	approx. 70 N	approx. 100 N
	1	0	1	approx. 80 N	approx. 110 N
	1	1	0	approx. 90 N	approx. 120 N
	1	1	1	approx. 100 N	approx. 130 N

#### 5.4 Programming the slave address

The slave address is programmed through the M12 connector. Any address from 1 to 31 can be set by means of the AS-i bus master or a hand-held programming device.

#### 5.5 Configuration of the safety monitor

The MZM 100 AS can be configured in the ASIMON configuration software with the following monitoring devices (also refer to the ASIMON manual).

##### Double channel dependent

- Synchronisation time: 0.1 s
- Optionally with startup test
- Optional with local acknowledge



The configuration of the safety monitor must be tested and confirmed by a qualified and authorised safety expert/safety engineer.

#### 5.6 Status signal "safety release"

The "safety release" status signal from a Safety at Work slave can be cyclically queried by the control system through the AS-i master. To that effect, the 4 input bits with the varying SaW code of a Safety at Work slave are evaluated through an OR operation with 4 inputs in the control system.

#### 5.7 Violent separation of solenoid interlock and actuator

The solenoid interlock has a latching force F of 500 N. When the actuator and the interlock are separated in an unauthorized and violent way, the safety guard is opened and the safety outputs are switched off within 100 ms. This is signalled through the yellow and red LED blinking alternatively.

To bring the system back to an operational condition, proceed in the following way:

- Close the safety guard
- Switch off the solenoid control once and then switch it back on (the yellow and red LED now flash simultaneously)
- Now wait for a safety time of 10 minutes to expire with the safety guard closed, until the LED's go out
- Switch the solenoid control once more off and on

**The device now is ready for operation again.**

### 6. Diagnostic

#### 6.1 LED indications

The LED's have the following meaning (to EN 50295):

LED green-red (AS-i Duo LED):	AS-Interface supply voltage/ AS-Interface communication error or slave address = 0 or periphery error
Red LED:	Internal device error
Yellow LED:	Device status

#### 6.2 Error

Errors, which no longer guarantee the safe functioning of the MZM 100 AS electromagnetic interlock, cause the safety outputs to be switched off and are signaled through a flashing pattern of the red LED. (see table 2)

After fault rectification, the error message can be reset by opening and closing the relevant guard door. The safety outputs of the safety monitor (ASM) can be switched back on, thus enabling the machine.

#### 6.3 Locking of the solenoid interlock blocked

When the interlocking function of the solenoid interlock is blocked and no latching force of at least 500 N could be generated, the MZM 100 AS will emit a warning message. This is signaled by the alternating red/green flashing of the AS-i duo LED on the device.

Possible causes for the blocked interlocking function:

- Solenoid soiled
- Guard incorrectly closed
- Too large a misalignment between the solenoid interlock and the actuator

6.4 Diagnostic information

**Table 1: Diagnostic information of the MZM 100 AS safety switchgear**

The safety switchgear signals the operational state as well as errors through three coloured LED's installed on both sides of the device.

System condition	Solenoid control	LED			Condition AS-i SaW-Code	
	AS-i DO 0	AS-i duo-LED	red Error	yellow Status	(DI 0 ... DI 3)	
Safety guard open	0	green	Off	Off	static 0	
Safety guard closed, actuator in	0	green	Off	Flashes	static 0	MZM 100 ST-AS
					dynamic	MZM 100 B ST-AS
Safety guard closed and locked	1	green	Off	On	dynamic	
Solenoid interlock cannot be locked, safety guard not correctly closed or solenoid soiled	1	red-green flashing	Off	Flashes	static 0	MZM 100 ST-AS
	0	red-green flashing	Off	off	static 0	MZM 100 B ST-AS
Internal device error	0/1	red-green flashing	Flashes <sup>1)</sup>	Off	static 0	
Violent separation of solenoid interlock and actuator (description, see 5.7)	0/1	red-green flashing	Flashes	Flashes	static 0	
AS-i error: slave address = 0 or communication error	0/1	red	depending on the condition		static 0	
Periphery error signaled through AS-i duo LED	0/1	red-green flashing	depending on the condition		static 0	

1) refer to flash code

**Table 2: Error messages / flash codes red LED**

Flash codes (red)	Designation	Autonomous switch-off after	Error cause
5 flash pulses	Actuator fault	0 min	incorrect or defective actuator
6 flash pulses	Latching force fault	0 min	Latching force has dropped below > 500 N (e.g. actuator misalignment)
10 flash pulses	Magnet temperature too high	0 min	The magnet is too hot: T > 70 °C
continuous red signal	internal error	0 min	Device defective

6.5 Diagnostic signal periphery error

All warnings or error messages of the MZM 100 AS are transmitted as "periphery error" to the control system through the AS-i master. The signal "periphery error" is a centralised alarm signal from warnings or error messages. The periphery error (FID input of the AS-i chip) is controlled together with parameter port P3. A "periphery error" is signaled by the alternating red and green flashing of the AS-i duo LED on the device.

6.6 Read-out of the parameter port

The parameter port P0 to P3 of an AS-i slave can be read out through the control interface of the AS-i master (see component description) by means of the "Write parameter" instruction (with hexadecimal value F). This (non-safe) diagnostic information from the reflected parameters or the answer to a "Write parameter instruction" can be used by the user for diagnostic purposes or for the control programme.

**Table 3: diagnostic information (P0...P3)**

Parameter bits	Condition = 1	Condition = 0
0	Actuator in, the solenoid interlock can be locked	Actuator not in
1	Solenoid interlock is locked	Solenoid interlock is not locked
2	Auxiliary voltage in	No auxiliary voltage
3	Warning or error detected	No error detected

7. Set-up and maintenance

7.1 Functional testing

The safety function of the safety components must be tested. The following conditions must be previously checked and met:

1. Check max. axial misalignment of actuator and safety switchgear
2. Check max. angular misalignment (see "Mounting" part)
3. Check the switch enclosure for damage
4. Remove particles of dust and soiling

7.2 Maintenance

We recommend a regular maintenance, including the following steps:

- Check the fixing of the safety switch and the actuator
- Check max. axial misalignment of actuator and safety switch
- Check max. angular misalignment (see "Mounting" part)
- Check the switch enclosure for damages
- Remove soiling

**Damaged or defective components must be replaced.**

8. Disassembly and disposal

8.1 Disassembly



The safety switchgear must be disassembled in a de-energised condition only.

8.2 Disposal

The safety switchgear must be disposed of in an appropriate manner in accordance with the national prescriptions and legislations.

9. Appendix

9.1 EC Declaration of conformity

	
<h2>EC Declaration of conformity</h2>	
Translation of the original declaration of conformity valid as of December 29, 2009	K.A. Schmersal GmbH Industrielle Sicherheitssysteme Mödinghofe 30, 42279 Wuppertal Germany Internet: www.schmersal.com
We hereby certify that the hereafter described safety components both in its basic design and construction conform to the applicable European Directives.	
<b>Name of the safety component / type:</b>	MZM 100 AS
<b>Description of the safety component:</b>	Interlocking device with electromagnetic interlock for safety functions
<b>Harmonised EC-Directives:</b>	2006/42/EC-EC-Machinery Directive 2004/108/EC EMC-Directive
<b>Person authorized for the compilation of the technical documentation:</b>	Ulrich Loss Mödinghofe 30 42279 Wuppertal
<b>Notified body, which approved the full quality assurance system, referred to in Appendix X, 2006/42/EC:</b>	TÜV Rheinland Industrie Service GmbH Alboinstr. 56 12103 Berlin ID n°: 0035
<b>Place and date of issue:</b>	Wuppertal, November 4, 2009
MZM 100 AS-B-EN	
	Authorised signature <b>Heinz Schmersal</b> Managing Director



The currently valid declaration of conformity can be downloaded from the internet at [www.schmersal.net](http://www.schmersal.net).



**K. A. Schmersal GmbH**  
**Industrielle Sicherheitssysteme**  
Mödinghofe 30, D - 42279 Wuppertal  
Postfach 24 02 63, D - 42232 Wuppertal

Phone: +49 - (0)2 02 - 64 74 - 0  
Telefax +49 - (0)2 02 - 64 74 - 1 00  
E-Mail: [info@schmersal.com](mailto:info@schmersal.com)  
Internet: <http://www.schmersal.com>